

# Lab 8 - DPSK

## Goal

An introduction into non-coherent signaling formats using differential phase shift keying (DPSK) which is a form of non-coherent equal energy orthogonal signaling.

## Pre- lab

### Reading

1. Section 7.9 in ZT.
2. Notes on DPSK.

### Problems and Simulations

1. *Differential encoding for DPSK*
  - a) Reproduce Table 7.3 for the 15 bit PRBS data stream used in Lab 3 using the same reference digit. There should be 16 values all together.
  - b) Given the transmitted phase from part (a), determine the pattern of the waveforms  $s_1(t)$  and  $s_2(t)$  detected at the receiver where  $s_1(t)$  and  $s_2(t)$  are defined in the notes.
  - c) Derive the recovered data pattern as a function of the detected patterns  $s_1(t)$  and  $s_2(t)$ .
2. Using the expressions for the error rate of the optimal DPSK receiver and the sub-optimal delay and multiply receiver given in the notes, determine the difference in error performance for a value of  $E_b/N_0 = 5$  dB. The curve in the notes can provide an estimate of the approximate value, but you are required to determine the exact value.
3. Starting with the “stripped down” section of the QPSK demod VI used last week and the QPSK PLL VI shown below, hand draw the modifications to implement the optimal DPSK receiver given in the notes. Use shift registers to implement the multiplications of the two values.

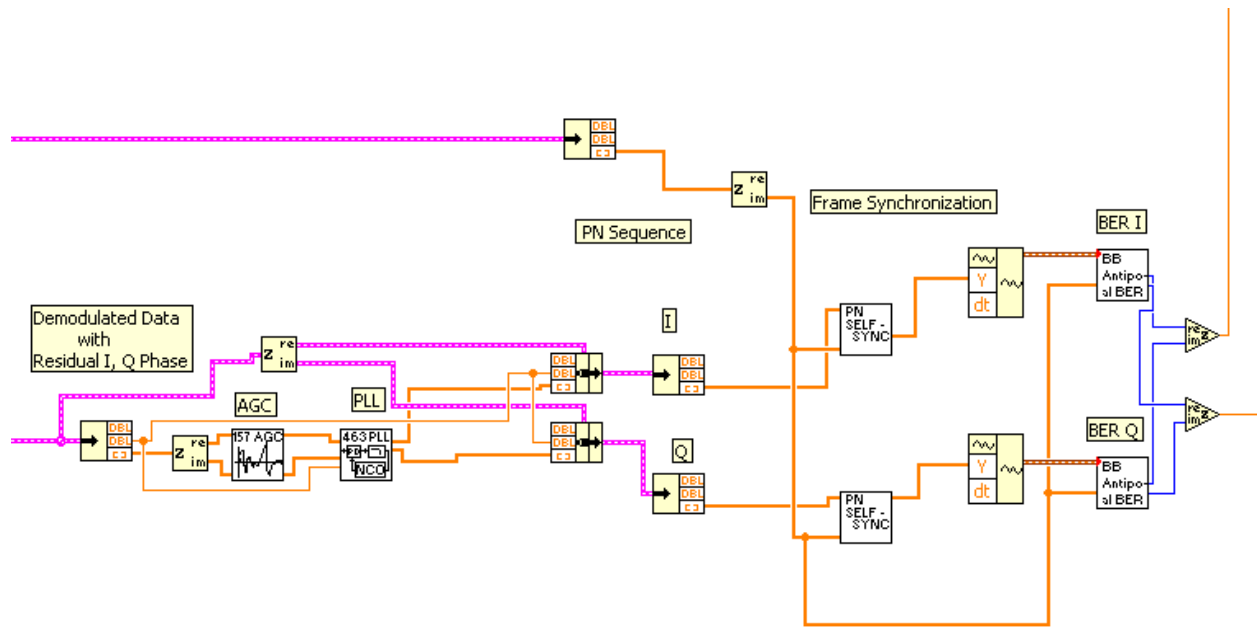

Stripped down QPSK demodulation VI.

## Lab

### 1 Differential Encoding

1. Start *DPSK\_Gen* VI and set the PRBS sequence length to 31 ( $2^5 - 1$ ). On the VI, the upper curve is the input digital sequence and the lower curve is the encoded antipodal sequence where +1 refers to no phase shift and  $-1$  refers to a  $\pi$  phase shift. The VI starts the encoding process at bit 29 using an initial “1” bit and displays the encoded waveform starting at about  $23 \times 10^{-4}$  on the upper curve.
2. Verify that by directly coding the data waveform starting at bit 29 using an initial “1” bit produces the upper waveform.
3. Compare the unencoded and coded waveforms and determine the difference in the number of blocks of 1 bit, 2 bits, 3 bits, 4 bits and 5 bits between the encoded and unencoded sequences.
4. Do you expect the spectrum of the encoded and unencoded spectrum to be the same or different?
5. Test your conclusions by using *Cal\_SA* measure and dump the DPSK spectrum along with the spectrum for BPSK. Be sure the set the span and resolution bandwidth so you can see the individual spectral lines.

### 2 BER for Optimal Receiver

1. Using the DPSK VI the TA provides measure the error rate for the optimal DPSK receiver. A sample data set is below.

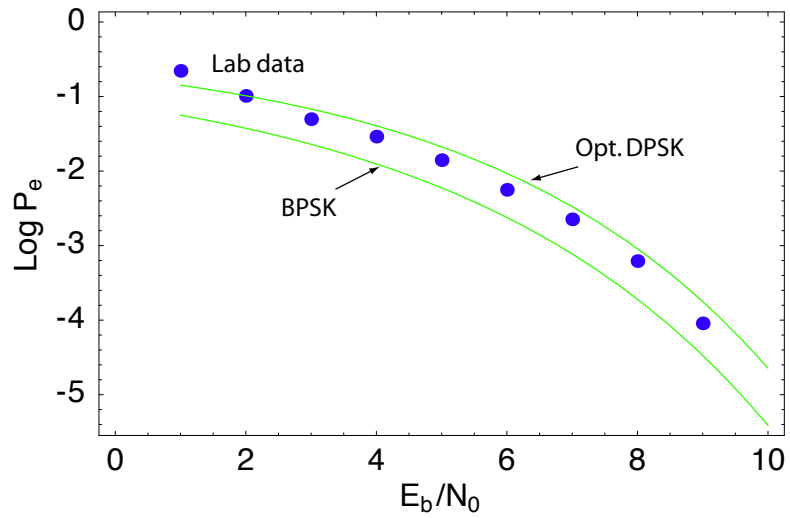

### 3 Post Lab

1. Compare the DPSK and BPSK spectra and comment on why they are the same or different based on the two types of transmitted waveforms.
2. On the same curve, plot experimental data for the BER vs.  $E_b/N_0$  from Lab 6 for BPSK along with the data for the optimal DPSK receiver. On the same curve, plot the theoretical curves for both cases and comment.